

INSTALLATION GUIDE

Sub Cill Installation

Drainage paths through the sub cill and must be free and left un-obstructed by the sub structure or sealing.

On conservatory/dwarf walls only, an additional fixing must be located as shown alongside to secure the frame into the sub cill. Seal under the head to prevent water ingress. Further seals should then be applied and sealed in suite.

Drainage Trays

Drainage paths through the sub cill must be left free and un-obstructed by the sub structure or sealing.

The drainage tray must be secured to the structure as shown, using suitable fixings and packed as necessary to ensure it is level.

The drainage tray must then be sealed to the structure along its length and across its ends. Care must be taken to ensure that the portion of the drainage tray that adjoins the jambs of the structure are adequately sealed, to prevent water running off each end of the drainage tray and in to the building.

When fitting the frame to the drainage tray silicon sealant must be gunned as shown alongside to ensure that the watertight joint is created on the inside of the frame.

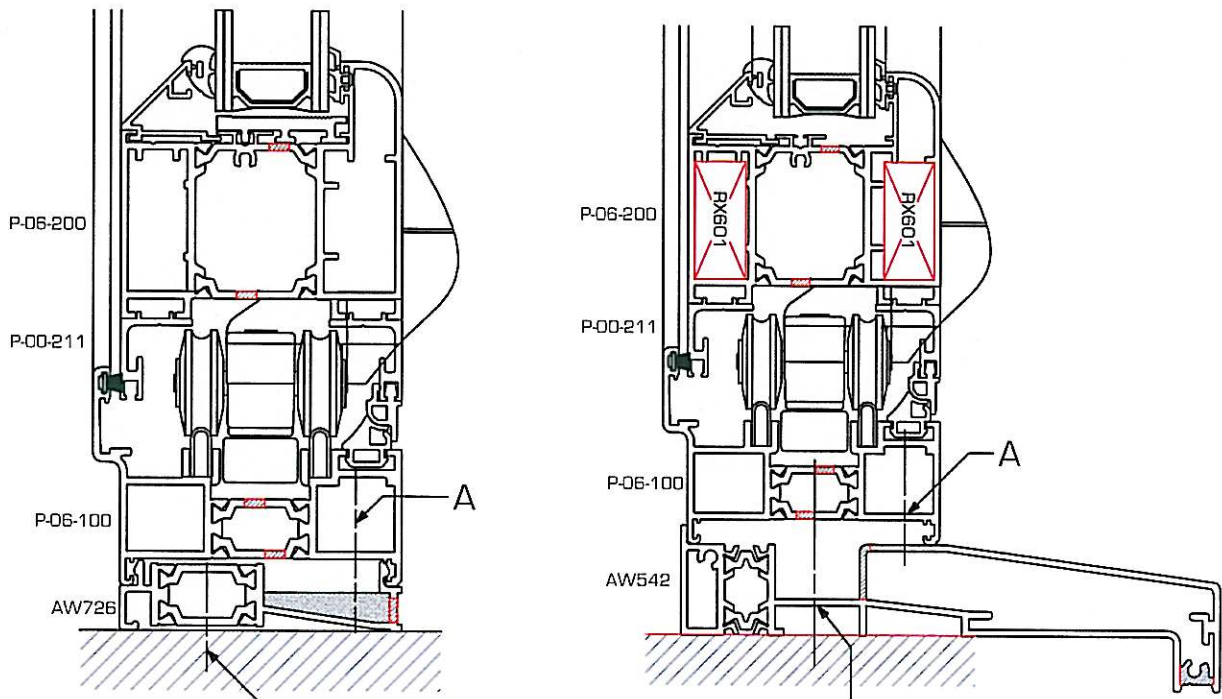

### Fitting Frame To Aperture

It is vitally important that the cill is laid flat and level to achieve the optimum performance. Jambs must be vertical in both planes, and no twist or other distortion allowed.

Prior to installing the frame, the opening should be checked to ensure that it is free of debris, and that any projecting brickwork has been trimmed back.

Any damaged damp proof membranes should be replaced or additional membranes incorporated.

When the opening was originally measured a suitable gap should have been allowed around the perimeter of the frame, this will allow the frame work to be packed to ensure that it is plumb and square within the opening.

Ideally the frame should be bedded on mortar.

The frame can then be positioned in the opening and held square by packing at the very corners, taking care not to damage or deform the profile.

### Tip #

To check for squareness, measure the diagonals from corner to corner, these diagonal dimensions should not differ by more than 1 to 2mm, if so adjusted the packing until the frame is square within the opening.

The lay of the frame in to out can be checked by using a spirit level on the jambs. On replacement applications, the correct position of the frame might not be aligned with the originals. This will require some remedial work to make good the plaster reveal around the frame on the internal wall as well as, any render externally.

### Fixing Frames

The first fixing must always occur within 150mm of each corner and at not more than 600mm centres (Do not over tighten fixings), the type and frequency depends on the expected applied loadings.

Packing will be required at fixing points to prevent distortion of the frame. Drilled holes in the frame should be sealed where there is a possibility of moisture penetration around the fastener.

### Foam

Fixing foam can be used in conjunction with fasteners, but is not an alternative to screw fixing.

Care must be taken not to allow the foam to come in contact with the painted finish, and as such the use of some form of masking tape would be advisable. Permanent staining will be caused if foam comes in contact with the frame.

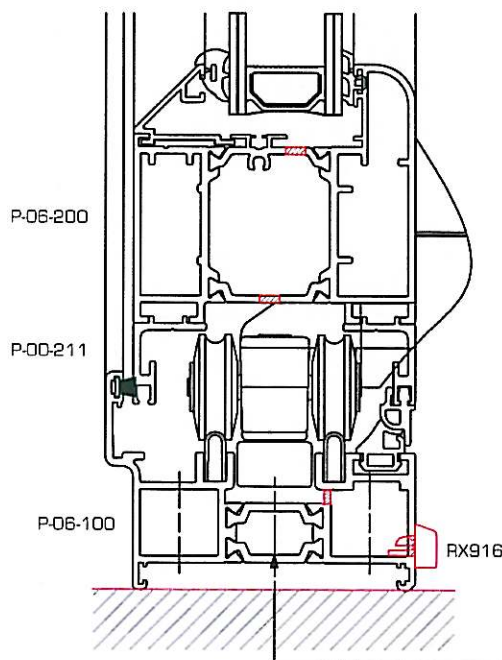

**IMPORTANT NOTE:** Always cap or seal fixings, especially when securing to any of the Blyweertbeaufort range of cills / drainage trays.

\*\*

Alternative Fixing Method  
i.e. Through Thermal Barrier

**NB:** Avoid leaving any screw head sitting proud as this may foul the top / bottom guides.

GLAZING

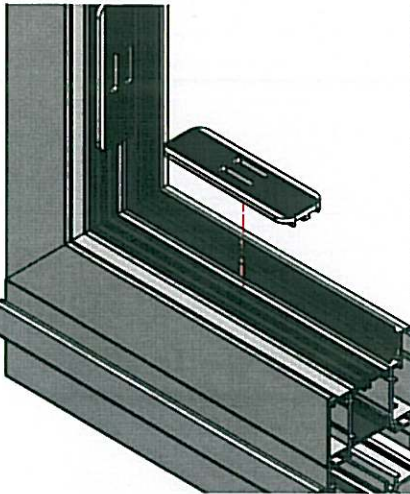
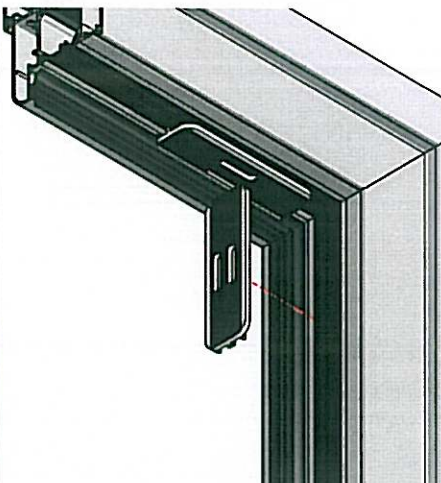
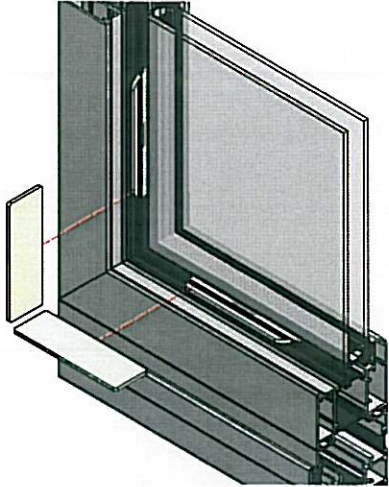
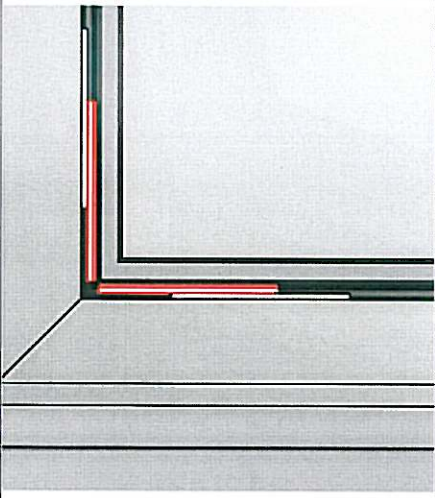
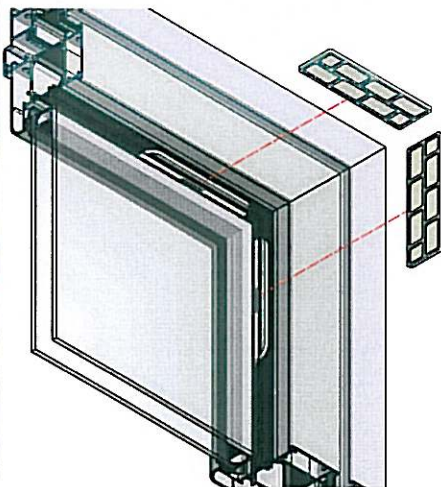
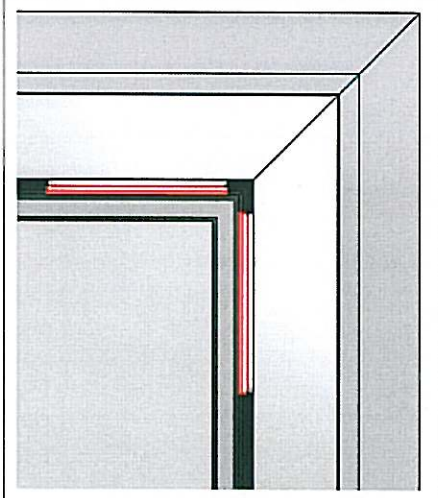
BOTTOM GLASS SUPPORT	GLASS SUPPORT ASSEMBLY	BOTTOM GLASS SUPPORT
		
<p>Place bridge packer on the hinge side along the bottom and vertical sections 150mm from the corner</p>	<p>Place bridge packers 150mm from the corner opposite the hinge side of the panel</p>	<p>Use glazing packers to 'heel' glass in place. Start at the bottom hinge side</p>
BOTTOM GLASS SUPPORT	GLASS SUPPORT ASSEMBLY	BOTTOM GLASS SUPPORT
		
<p>Bottom packers highlighted in RED support the weight of the glass</p>	<p>Pack the opposite upper corner of the non-hinge side of the panel</p>	<p>The upper packers re-distribute the weight of the glass back towards the outer-frame</p>

TOE & HEEL TYPE CONFIGURATIONS

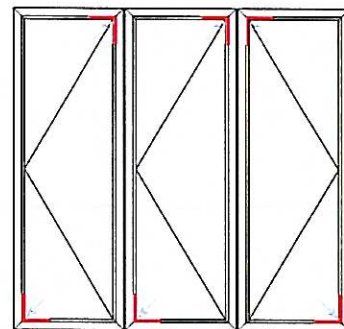
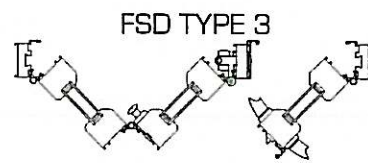
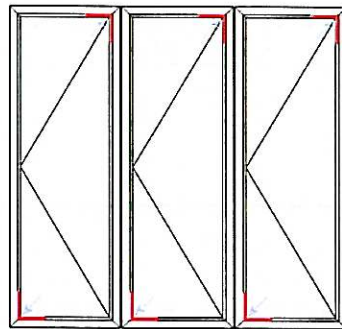
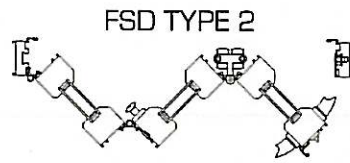
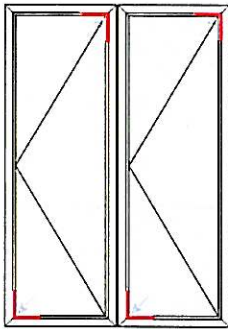
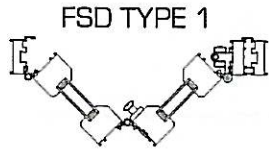

FSD TYPE 4

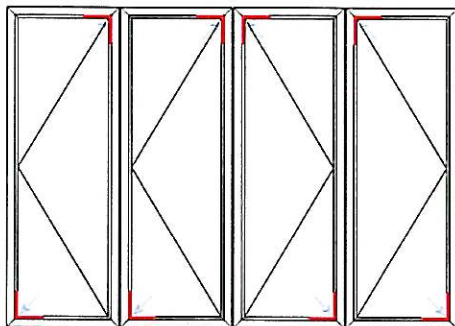
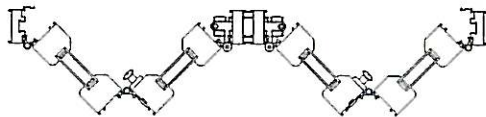

FSD TYPE 5

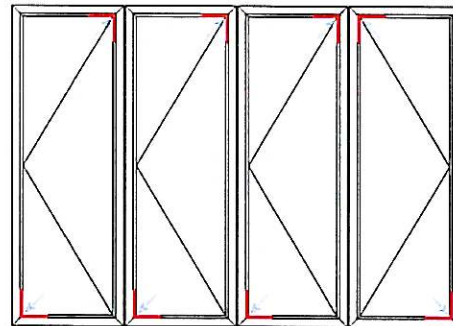
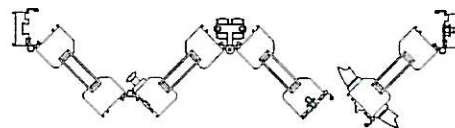

FSD TYPE 6

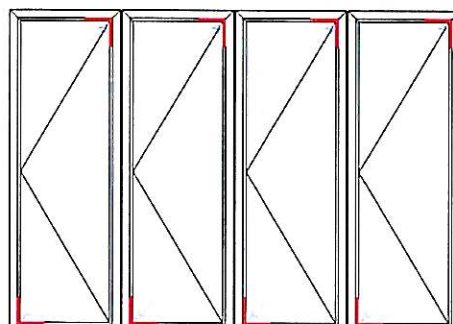
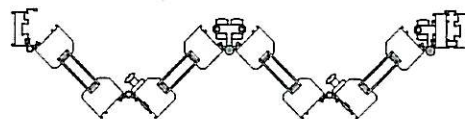

# beaufort

Range

# Advanced Plus

FSD

FSD TYPE 7

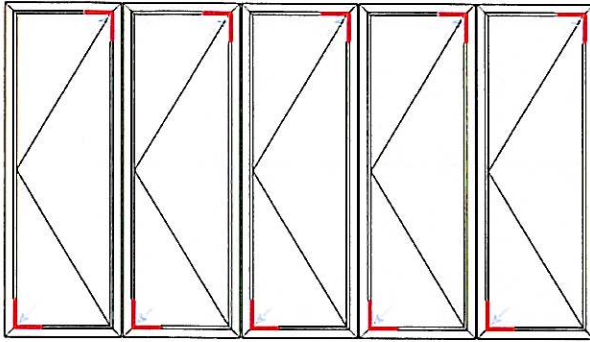
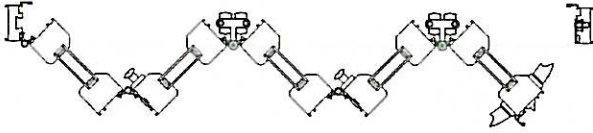

FSD TYPE 8

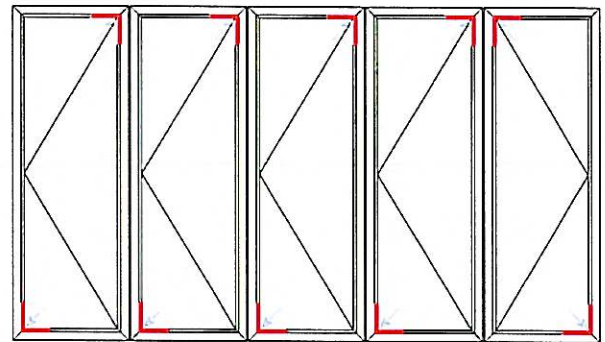
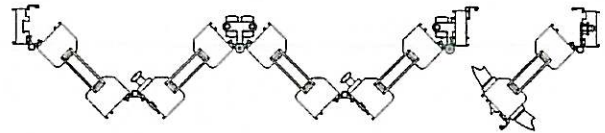

FSD TYPE 9

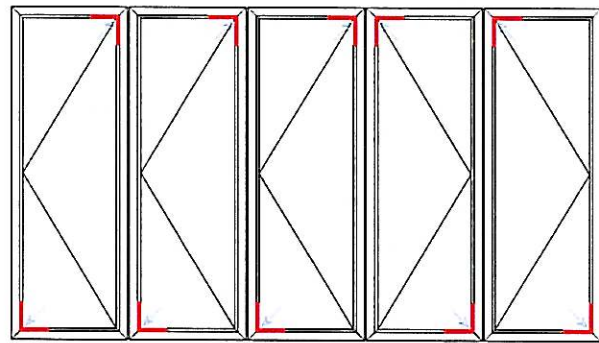
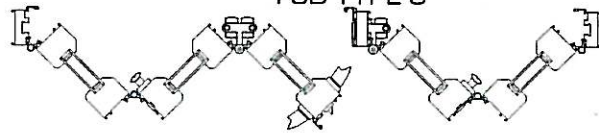

FSD TYPE 11

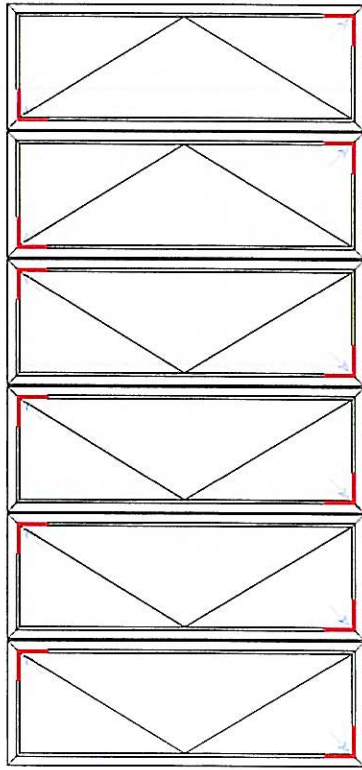
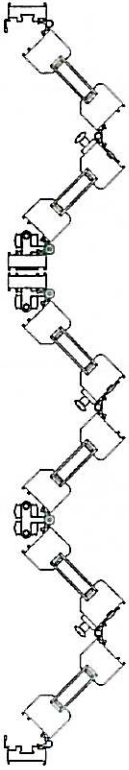

FSD TYPE 13

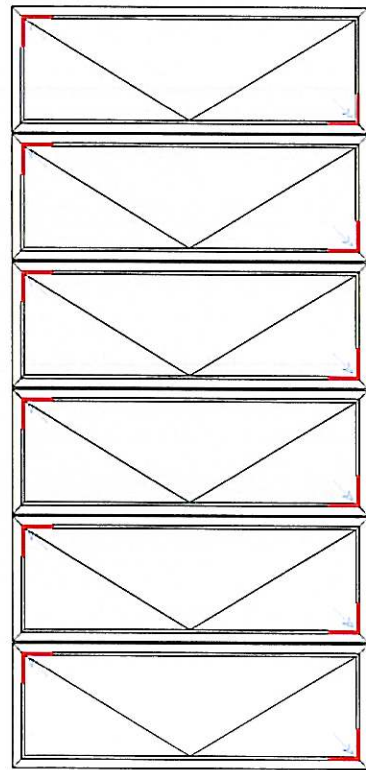
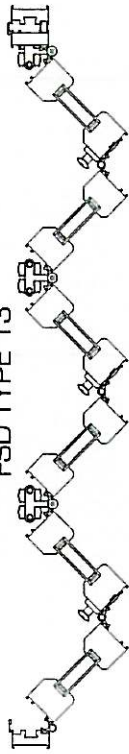

FSD TYPE 10

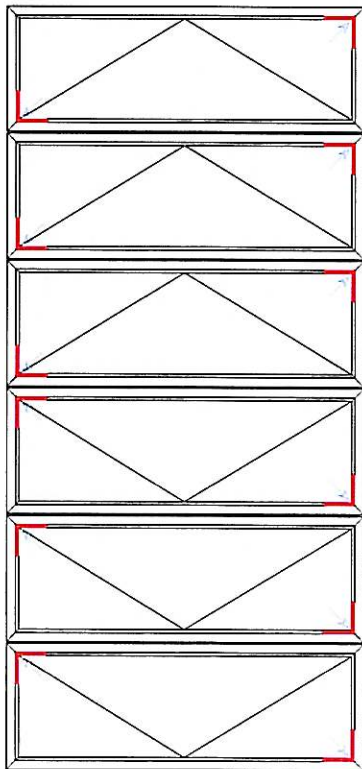

FSD TYPE 12

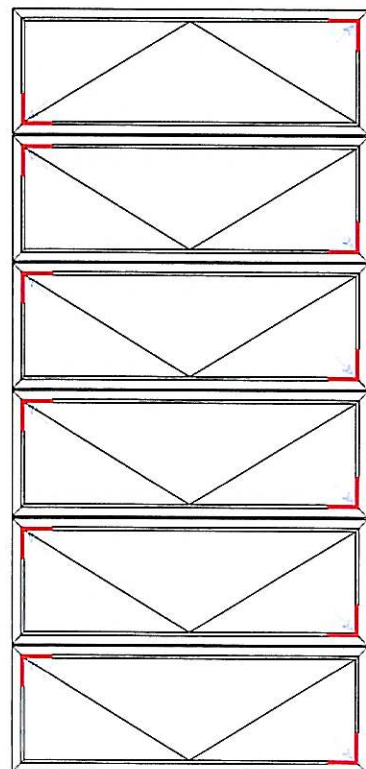
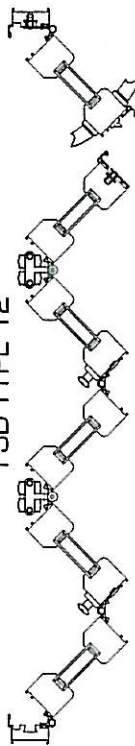

### Range

FSD TYPE 15

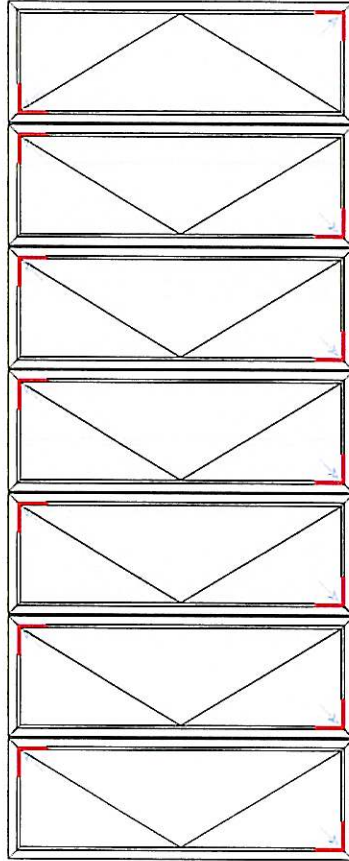
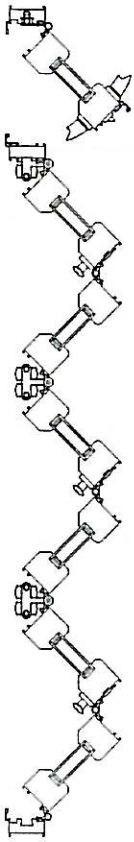

FSD TYPE 17

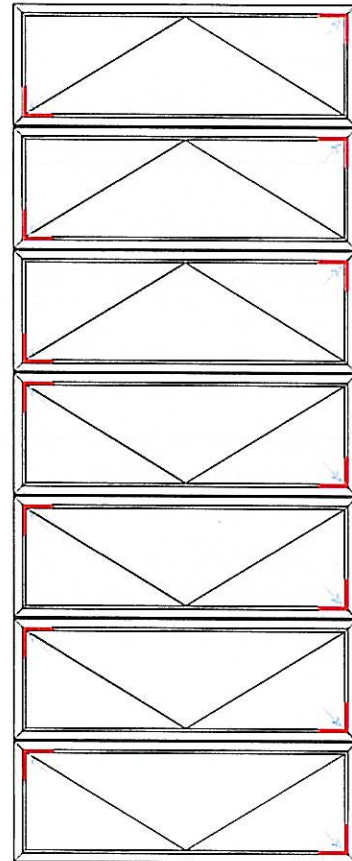
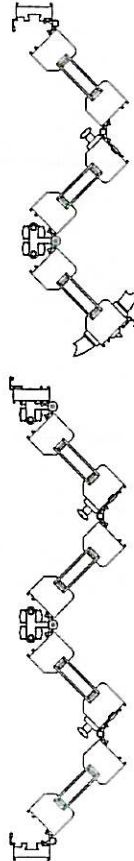

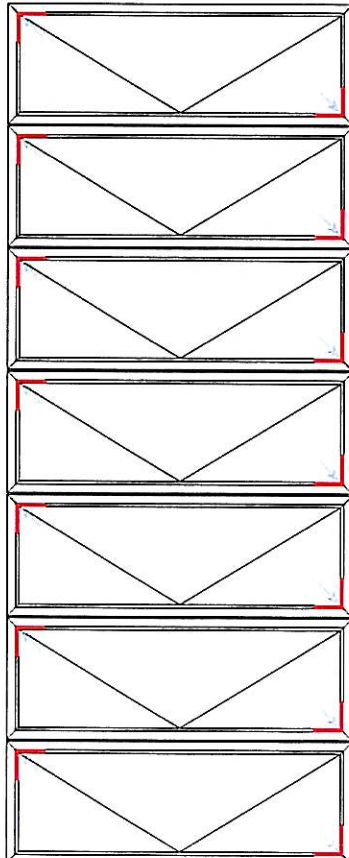
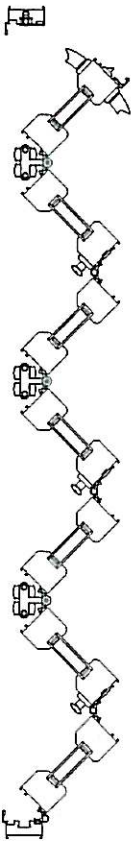

FSD TYPE 14

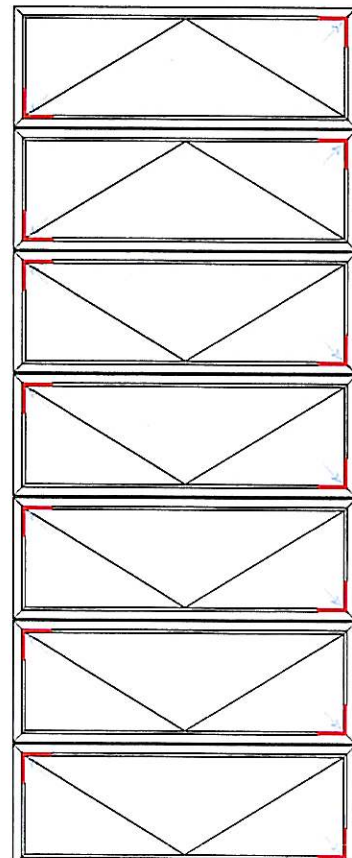
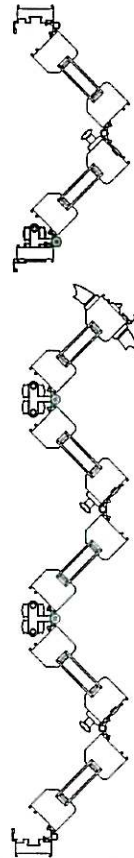

FSD TYPE 16

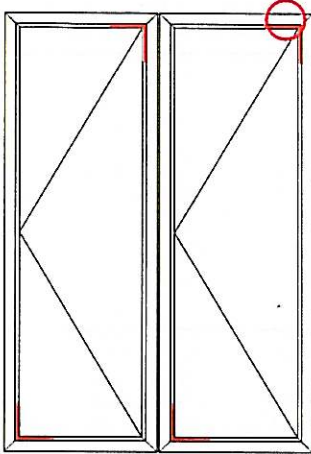
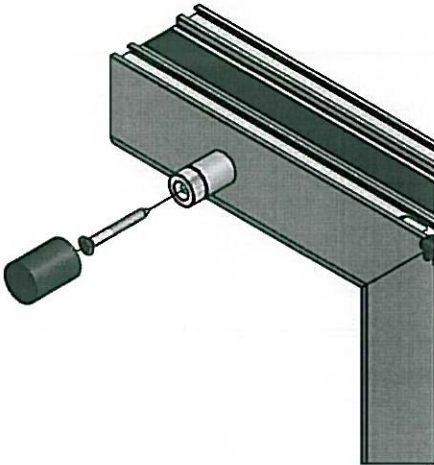
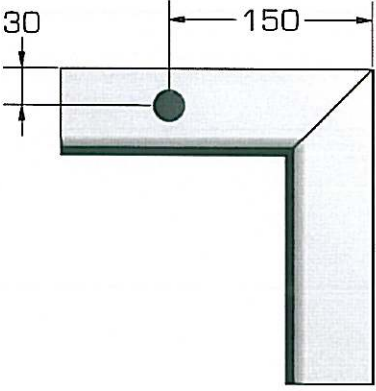

PANEL RETENTION

MAGNET LOCATION	MAGNET FITTING	MAGNET LOCATION
		
<p>Bottom packers highlighted in RED support the weight of the glass</p>	<p>Screw magnet to door using screw provided</p>	<p>Magnet location as above</p>
<p>MAGNET FITTED</p>		
		
<p>Located at the top of connected panels</p>		